

CARE AND MAINTENANCE INSTRUCTIONS FOR MARINER, MARINER II, AND WORKHORSE II SLIDES

The seat slides furnished by Springfield Marine Company are designed to provide years of trouble-free, maintenance-free use. Because of these designs, there are no periodic maintenance requirements, other than making sure they don't get excessively dirty. However, we do recommend the following inspections on a regular basis.

1. Check the various operating handles to ensure that they are screwed in tightly and operate smoothly. The handle assemblies are greased using N.L.G.I #2 marine grade lithium grease. Check to ensure that the grease has not hardened or drawn in contaminants. Any excess grease showing on the pin when it is locked should be cleaned off. Should the handles become difficult to pull out a small amount of Silver Grade Anti-Seize such as LocTite 76764 can be applied to the end of the pin. This will require removal of the handle assembly by unscrewing it from the slide.
2. For Mariner and Mariner II slides ensure that the Swivel Tension Pin is tight at all times. Workhorse II slides require loosening of the handle for operation and only require the handle to be tight when desired
3. For Workhorse II slides there is a composite washer that separates the swivel from the top of the pedestal. Any time the slide is removed from the pedestal ensure that this washer is reinstalled into the bottom of the swivel. N.L.G.I #2 marine grade lithium grease can be used to hold it in place during installation and will allow the slide to rotate smoothly.
4. These slides are assembled using thread locker. However a periodic check the fasteners that hold the various components in place will ensure that the slide remains stable and movement free.
5. The Mariner and Mariner II slides are equipped with an adjustment feature. This allows the user to set the desired rotational tension and remove any rotational movement when the slide is locked. The adjustment screws are located on the swivel cover as shown. To adjust, turn the three jam nuts counter clockwise one turn. Tighten the 3 set screws to the desired tension. Holding the set screw in place with an allen key tighten the jam nut by turning clockwise. Workhorse II slides are bolted solid and do not have this feature.

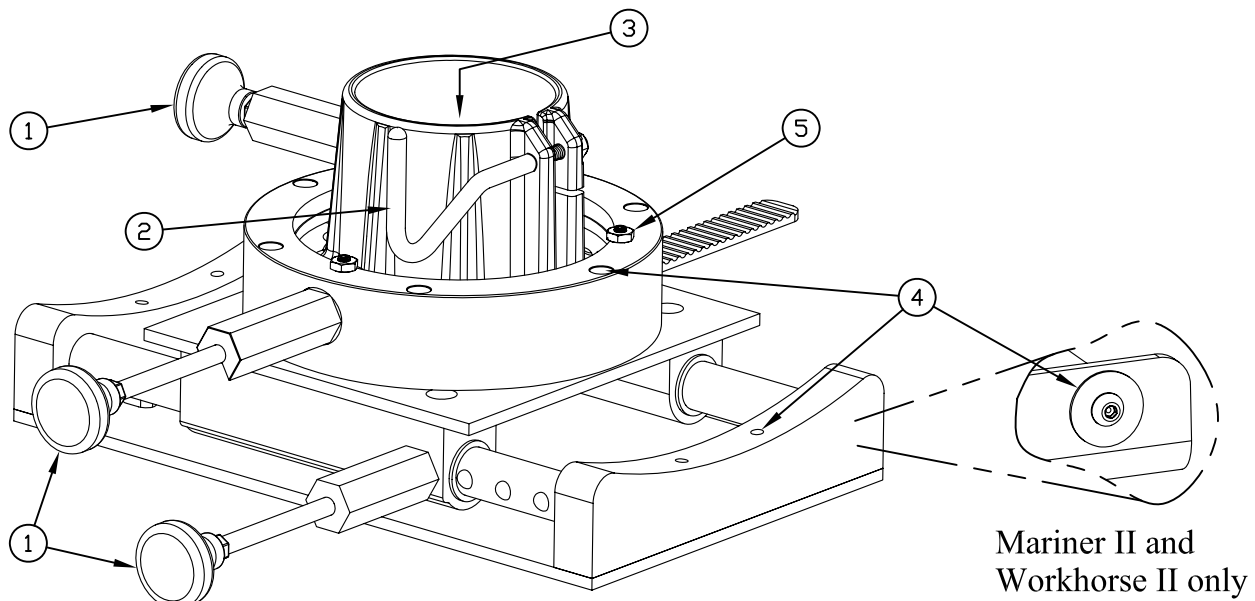

Mariner Slide shown, others are similar.